

TOSHIBA

SERVICE MANUAL

VIDEO CASSETTE RECORDER
V-212EF



8. Block Diagram

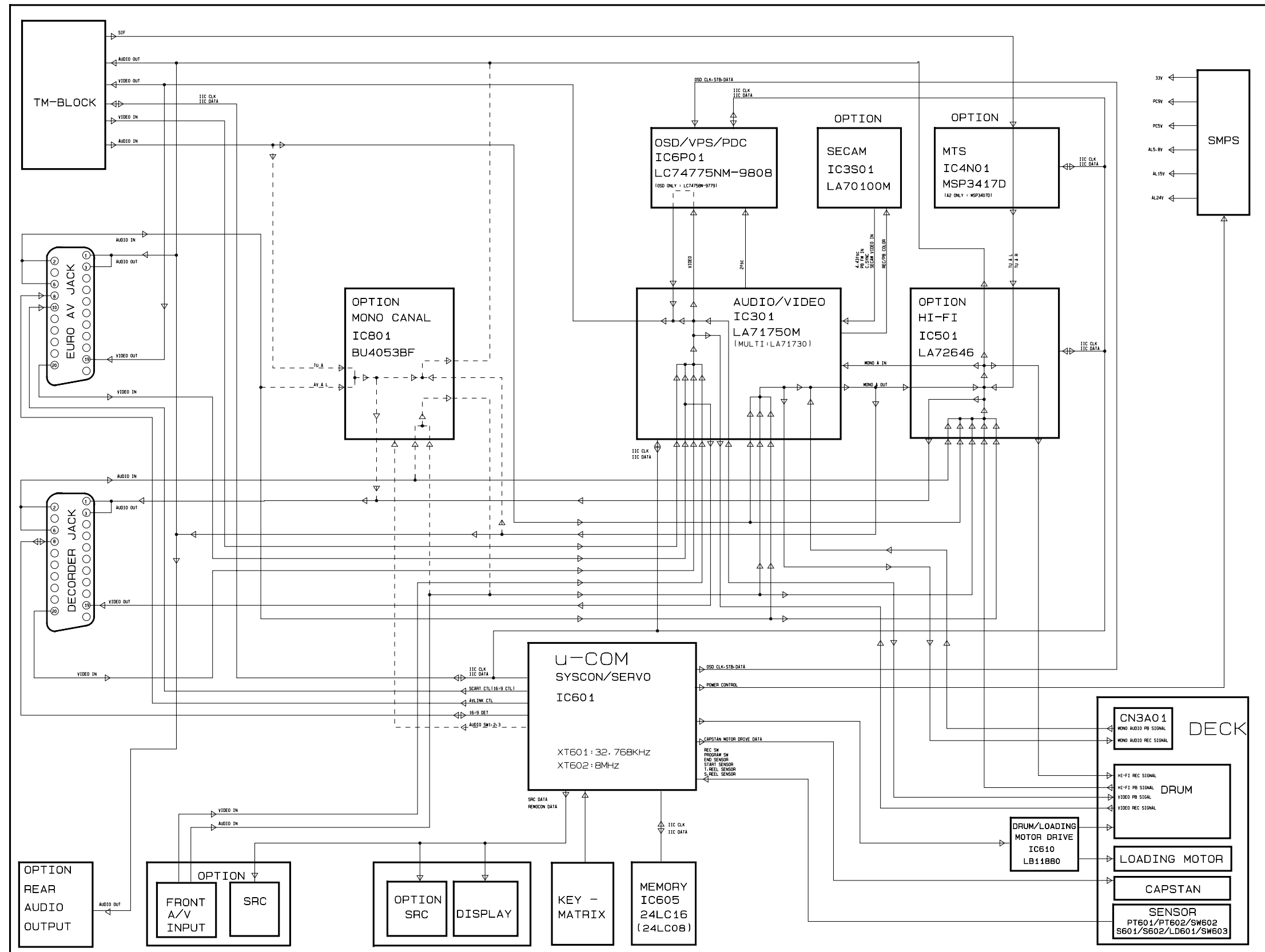

MEMO

9. PCB Diagrams

9-1 Main 9-2

9-1 Main

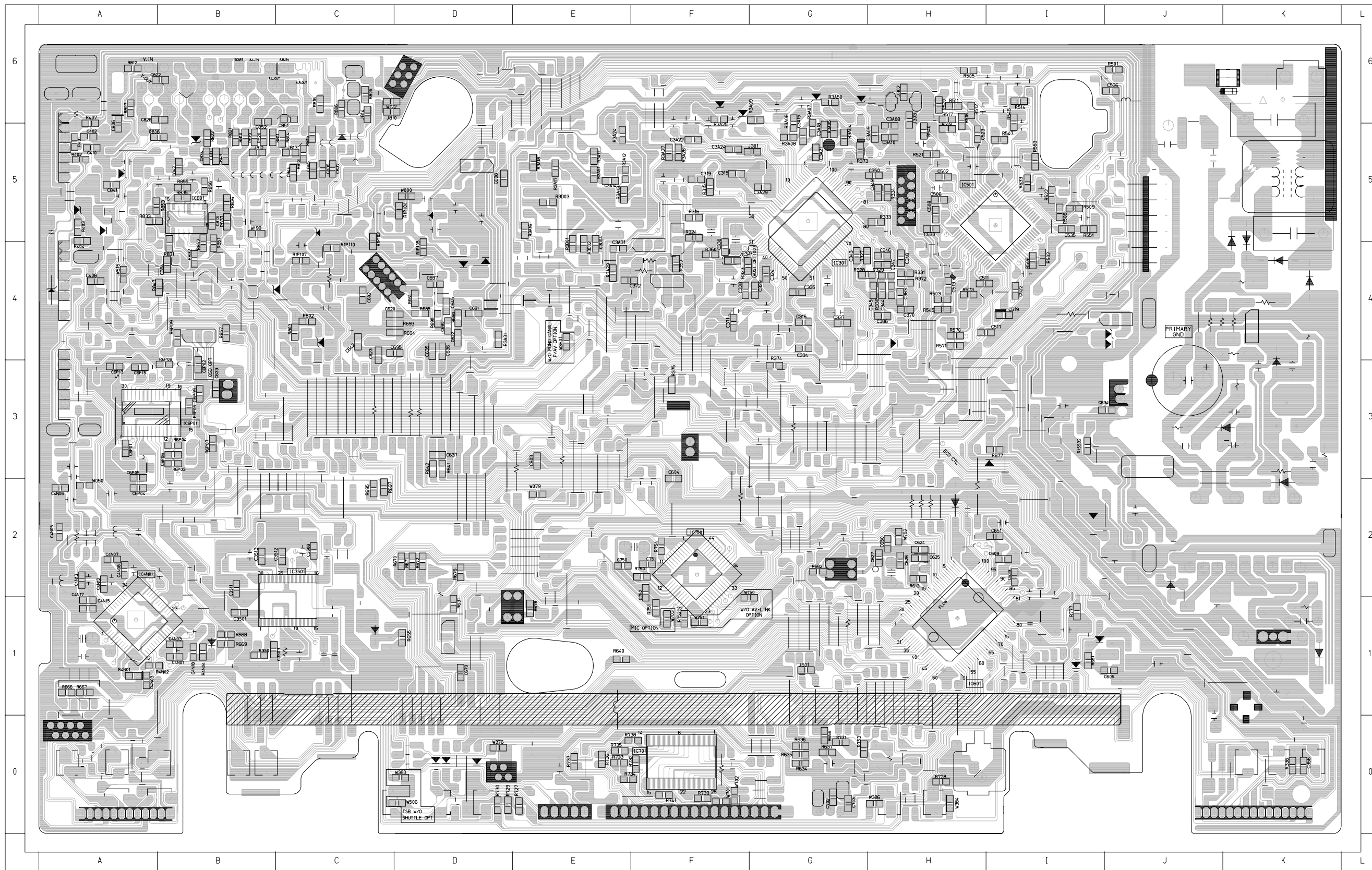

BD1SD1 (J6)	C3S06 (C1)	C802 (B4)	L1SS32 (K1)	R1P108 (C4)	R3D04 (E4)	TP302 (J5)	W064 (G0)	W135 (F3)	W215 (D1)	W322 (F3)	W421 (H4)	ZD808 (A5)
BD1SR1 (K3)	C3S07 (C2)	C804 (B4)	L301 (F5)	R1SD11 (K4)	R408 (A5)	TP303 (J5)	W065 (E2)	W136 (G3)	W216 (A4)	W324 (D6)	W422 (G5)	ZD809 (A5)
BD1SS1 (K2)	C3S09 (C2)	C805 (B4)	L302 (F4)	R1SD12 (K3)	R4N05 (A2)	TP601 (J4)	W066 (G0)	W137 (F3)	W217 (B5)	W325 (E5)	W425 (G3)	ZD810 (F5)
BD1SS2 (J1)	C3S10 (B1)	C809 (B5)	L370 (H4)	R1SD13 (K4)	R507 (I5)	TP602 (J5)	W067 (F0)	W138 (G3)	W218 (A4)	W326 (E5)	W426 (C5)	ZD811 (F5)
C1P102 (C4)	C3S14 (B2)	C810 (B5)	L3A01 (H5)	R1SD14 (J4)	R510 (I6)	VA1SS1 (K5)	W069 (C2)	W139 (G3)	W220 (B4)	W328 (J2)	W427 (C5)	ZD812 (G6)
C1P103 (C4)	C3S15 (C1)	C812 (B5)	L3A02 (F5)	R1SD15 (J4)	R516 (C5)		W070 (B3)	W140 (G3)	W221 (B5)	W329 (H3)	W428 (C5)	ZD813 (G6)
C1P104 (D5)	C401 (A4)	C814 (B5)	L3A03 (F5)	R1SD16 (J3)	R550 (I5)	W002 (J0)	W071 (B3)	W141 (F3)	W222 (C6)	W330 (G3)	W429 (C5)	
C1P105 (D5)	C403 (A5)	C815 (B5)	L3A50 (E5)	R1SD31 (J2)	R552 (I5)	W003 (K0)	W072 (E3)	W142 (F3)	W223 (B6)	W332 (G3)	W430 (I6)	
C1P106 (D5)	C404 (A2)	C821 (A5)	L3D01 (E5)	R1SD32 (J2)	R601 (H2)	W004 (J0)	W073 (C3)	W143 (G3)	W224 (B5)	W333 (H6)	W431 (I6)	
C1P108 (D5)	C405 (I3)	CN1SS1 (K6)	L402 (A4)	R1SR11 (K4)	R602 (H2)	W005 (I1)	W074 (C3)	W145 (H3)	W225 (C6)	W334 (C4)	W432 (J5)	
C1P109 (C5)	C406 (A4)	CN701 (A0)	L4N01 (A1)	R1SR12 (K4)	R603 (H2)	W006 (I1)	W075 (B2)	W146 (H2)	W226 (C5)	W335 (D4)	W433 (J5)	
C1P120 (C4)	C407 (A5)	CN703 (A0)	L4N02 (A2)	R1SR14 (K3)	R604 (D0)	W007 (I1)	W076 (C3)	W147 (H3)	W227 (C6)	W336 (D4)	W437 (H4)	
C1SD03 (J5)	C4N02 (B1)	CN708 (J0)	L4N03 (A2)	R1SS03 (K1)	R605 (I3)	W008 (I1)	W077 (C3)	W149 (H3)	W228 (C0)	W337 (D4)	W438 (A3)	
C1SD04 (J5)	C4N04 (B1)	CN709 (E0)	L4N04 (B1)	R1SS10 (K4)	R607 (I1)	W009 (I1)	W078 (C3)	W151 (G2)	W229 (C0)	W338 (E2)	W439 (A5)	
C1SD11 (J3)	C4N09 (B2)	CN301 (H5)	L501 (I3)	R1SS11 (K3)	R608 (D3)	W010 (I1)	W080 (C3)	W152 (H2)	W23 (J4)	W339 (D4)	W440 (H6)	
C1SD12 (J3)	C4N10 (A2)	CN3A01 (C6)	L502 (I6)	R3S02 (C1)	R609 (C3)	W011 (H0)	W081 (D4)	W154 (J2)	W230 (C0)	W340 (E4)	W441 (H6)	
C1SD13 (K3)	C4N11 (A2)	CN3A02 (I4)	L602 (H2)	R406 (A5)	R610 (I1)	W012 (H0)	W082 (C3)	W155 (H2)	W231 (B0)	W342 (H4)	W442 (C2)	
C1SR12 (K4)	C4N14 (A2)	CN3A15 (D6)	L603 (D4)	R4N06 (A2)	R611 (H0)	W013 (J1)	W083 (E4)	W157 (I2)	W232 (B0)	W343 (I4)	W443 (F3)	
C1SR14 (K3)	C4N16 (A1)	CN604 (C4)	L6P03 (B3)	R630 (D1)	R614 (G1)	W014 (H0)	W084 (A4)	W158 (I2)	W233 (B0)	W344 (A3)	W444 (C4)	
C1SS01 (K6)	C4N19 (A2)	CN702 (D0)	L6P05 (A3)	R657 (H0)	R632 (F0)	W015 (H0)	W085 (D4)	W161 (I2)	W234 (A0)	W345 (C5)	W450 (G2)	
C1SS02 (K5)	C4N21 (A1)	CN703S (A0)	L701 (E0)	R692 (J1)	R638 (I1)	W016 (H0)	W086 (C3)	W163 (D0)	W235 (A0)	W346 (H4)	W501 (B2)	
C1SS03 (K1)	C4N22 (A1)	CON/B (C6)	L803 (C5)	R1P101 (I2)	R639 (I1)	W017 (H0)	W087 (C3)	W164 (H4)	W236 (A0)	W347 (I6)	W502 (A4)	
C1SS12 (K3)	C4N23 (A2)	D1P101 (D4)	L804 (C5)	R1P103 (I4)	R644 (H2)	W018 (G0)	W088 (H3)	W165 (D0)	W237 (A0)	W348 (H3)	W503 (C3)	
C1SS13 (K3)	C4N24 (A3)	D1P102 (J4)	L805 (B5)	R1P106 (D3)	R654 (C1)	W019 (G0)	W089 (B4)	W166 (H4)	W238 (B1)	W350 (J4)	W504 (C2)	
C1SS31 (J2)	C4N25 (A2)	D1P103 (D4)	L806 (B5)	R1P109 (C3)	R660 (D3)	W020 (G0)	W090 (A5)	W167 (H3)	W239 (B2)	W351 (B2)	W507 (E4)	
C1SS32 (J2)	C4N26 (A3)	D1SD11 (K2)	L807 (C5)	R1P115 (D4)	R674 (H0)	W021 (G0)	W091 (D3)	W168 (D0)	W241 (D1)	W352 (I5)	W510 (I3)	
C1SS33 (K1)	C4N30 (A2)	D1SD31 (J2)	L808 (B5)	R1SS33 (I3)	R675 (F2)	W022 (G0)	W092 (B4)	W169 (D0)	W242 (D2)	W353 (H3)	W512 (H5)	
C1SS34 (K1)	C501 (H5)	D1SR11 (K4)	L809 (C5)	R1SS34 (I3)	R679 (D1)	W023 (G0)	W093 (C2)	W17 (J2)	W243 (D2)	W354 (D1)	W513 (H4)	
C1SS35 (J1)	C503 (H5)	D1SS01 (K4)	L810 (C5)	R320 (E2)	R680 (G2)	W024 (H1)	W094 (H3)	W170 (D0)	W244 (D2)	W355 (B2)	W514 (B4)	
C1SS36 (J1)	C504 (H5)	D1SS02 (K5)	L811 (B5)	R321 (G3)	R691 (G2)	W025 (H1)	W095 (C2)	W171 (E4)	W245 (D2)	W356 (F2)	W520 (C2)	
C1SS39 (J3)	C505 (H5)	D1SS03 (K4)	L812 (B5)	R322 (E2)	R696 (C3)	W026 (H1)	W096 (F0)	W173 (D0)	W246 (D2)	W357 (F2)	W521 (C2)	
C317 (F5)	C507 (H5)	D1SS04 (K4)	L814 (A5)	R325 (H4)	R6P01 (A2)	W027 (G1)	W097 (F0)	W174 (E4)	W247 (D2)	W358 (E4)	W522 (B2)	
C318 (F5)	C510 (H4)	D1SS11 (J3)	LD601 (F3)	R326 (H4)	R6P02 (A3)	W028 (J0)	W098 (E1)	W175 (F4)	W248 (D2)	W359 (D0)	W531 (A1)	
C320 (F5)	C518 (I4)	D1SS31 (J2)	LD601A (F3)	R335 (B3)	R6P05 (A3)	W029 (G1)	W099 (E1)	W176 (F4)	W249 (D2)	W361 (F5)	W532 (A0)	
C321 (F5)	C520 (I4)	D1SS32 (K1)	PT1SS1 (J2)	R370 (E4)	R6P10 (B3)	W030 (G1)	W100 (E1)	W177 (E4)	W250 (B3)	W362 (E5)	W533 (A0)	
C322 (F5)	C521 (I4)	D1SS33 (K1)	PT601 (D1)	R371 (B4)	R740 (F0)	W031 (G0)	W101 (E2)	W178 (E3)	W251 (D2)	W363 (C5)	W534 (A0)	
C325 (G4)	C524 (I5)	D301 (H4)	PT602 (G2)	R3A01 (G3)	R809 (A5)	W032 (I1)	W102 (D3)	W179 (E6)	W252 (D2)	W364 (E2)	W535 (B0)	
C326 (F4)	C525 (I5)	D302 (I3)	Q1P101 (D5)	R3A14 (E4)	R828 (A5)	W033 (G1)	W103 (E0)	W18 (J3)	W253 (D3)	W365 (F2)	W555 (K0)	
C327 (F4)	C526 (H5)	D410 (D6)	Q1P102 (D5)	R3A23 (F5)	R839 (A5)	W034 (G1)	W104 (E4)	W180 (A4)	W254 (D4)	W366 (F2)	W556 (F5)	
C332 (G4)	C527 (H5)	D4N01 (D2)	Q1P103 (D5)	R3A26 (F5)	R842 (F4)	W035 (E0)	W105 (G2)	W182 (E4)	W255 (C2)	W367 (B4)	W557 (J5)	
C333 (G4)	C529 (H6)	D4N02 (B1)	Q1P104 (C4)	R3A32 (F5)	RM701 (G0)	W036 (I2)	W106 (D2)	W183 (E4)	W256 (C2)	W368 (B5)	W558 (I3)	
C336 (G3)	C537 (I5)	D601 (J1)	Q1P105 (C4)	R3A33 (E4)	R5601 (H0)	W037 (H2)	W107 (E2)	W185 (E4)	W258 (B2)	W369 (A4)	W660 (I3)	
C338 (G4)	C538 (I5)	D603 (I1)	Q1P106 (D4)	R3A60 (F5)	S601 (J3)	W038 (G2)	W108 (E2)	W186 (D0)	W259 (B2)	W370 (E4)	W704 (G1)	
C339 (G4)	C539 (I6)	D604 (C1)	Q1P107 (C5)		S601A (J3)	W039 (E0)	W109 (E2)	W187 (D5)	W260 (E2)	W371 (A5)	W705 (G2)	
C340 (G4)	C540 (I6)	D612 (H2)	Q1P108 (J4)		S602 (B3)	W040 (H3)	W110 (I4)	W188 (D4)	W270 (K0)	W372 (I4)	W706 (G3)	
C341 (F5)	C541 (H4)	D701 (D0)	Q1SR01 (K3)		S602A (B3)	W041 (E1)	W111 (D3)	W189 (H3)	W271 (D4)	W373 (I5)	W759 (H5)	
C342 (F5)	C542 (I4)	D702 (D0)	Q1SR02 (K4)		SC01 (K3)	W042 (G1)	W112 (D3)	W190 (C4)	W300 (B4)	W374 (H3)	W760 (B4)	
C351 (G5)	C601 (C4)	D703 (D0)	Q302 (F5)		SC02 (K1)	W043 (E5)	W113 (D5)	W192 (A5)	W301 (B4)	W377 (A6)	XT301 (F5)	
C352 (F4)	C607 (J1)	D704 (I1)	Q350 (F4)		SW601 (C2)	W044 (C0)	W114 (D3)	W194 (C5)	W302 (F3)	W378 (H5)	XT302 (F5)	
C353 (F4)	C608 (J0)	D805 (C5)	Q351 (B4)		SW701 (K0)	W045 (G2)	W115 (D3)	W195 (C5)	W303 (B4)	W381 (C2)	XT4N01 (A1)	
C354 (F4)	C611 (C1)		Q3A01 (G6)		SW702 (K0)	W046 (G0)	W116 (D5)	W196 (C5)	W305 (A4)	W382 (I4)	XT602 (H2)	
C355 (G4)	C618 (C4)		Q3A02 (E6)		SW703 (K0)	W047 (H0)	W117 (B2)	W198 (A3)	W306 (A4)	W385 (D0)	XT750 (F2)	
C357 (B2)	C638 (I2)	DT701 (F0)	Q3A03 (F5)		SW708 (H0)	W048 (A0)	W118 (E3)	W200 (F4)	W307 (E5)	W403 (G5)	XT601 (H2)	
C380 (F3)	C640 (I2)	FC1SS1 (K6)	Q3A04 (E5)		SW709 (H0)	W049 (A2)	W119 (E3)	W201 (D0)	W308 (A3)	W405 (I3)	ZD1P01 (J4)	
C382 (G4)	C641 (I2)	FC1SS2 (J6)	Q3A05 (E5)		SW710 (E0)	W051 (C5)	W120 (B2)	W202 (D0)	W309 (A3)	W406 (E5)	ZD1P02 (D5)	
C3A01 (F5)	C644 (G2)	FL3A01 (E5)	Q3A06 (E5)		SW711 (D0)	W052 (A3)	W122 (E3)	W203 (C6)	W310 (A3)	W407 (G4)	ZD1P03 (D4)	
C3A02 (F5)	C646 (I1)	FL3D01 (F5)	Q3D01 (E5)		SW712 (D0)	W053 (H0)	W123 (F3)	W204 (C5)	W311 (A4)	W408 (H4)	ZD1P04 (C5)	
C3A11 (E5)	C652 (A1)	GP301 (H6)	Q3D02 (E5)		SW713 (D0)	W054 (J2)	W124 (E0)	W205 (C5)	W312 (A4)	W409 (F3)	ZD1SS1 (I2)	
C3A12 (E5)	C655 (H2)	HS01 (K3)	Q3D07 (F4)		SW714 (B0)	W055 (G0)	W125 (G2)	W206 (B4)	W313 (B4)	W410 (F3)	ZD401 (A4)	
C3A16 (G6)	C680 (I1)	HS02 (K1)	Q601 (D1)		SW715 (A0)	W056 (B3)	W126 (H3)	W207 (D0)	W314 (A4)	W411 (F3)	ZD801 (C4)	
C3A17 (G6)	C681 (I2)	IC1SS1 (J3)	Q602 (C1)		SW716 (A0)	W057 (G5)	W127 (G2)	W208 (H6)	W315 (A3)	W412 (E3)	ZD802 (A5)	
C3A23 (F5)	C692 (D4)	IC1SS2 (I3)	Q603 (D5)		SW717 (B0)	W058 (H0)	W128 (G2)	W209 (B4)	W316 (A4)	W413 (G4)	ZD803 (A5)	
C3A30 (G5)	C693 (E0)	IC604 (J1)	Q6P01 (B3)		SW718 (A0)	W059 (B2)	W129 (G2)	W210 (D1)	W317 (A5)	W414 (G4)	ZD804 (A5)	
C3A40 (G6)	C6P07 (B3)	IC608 (H0)	Q6P02 (B4)		SW719 (B0)	W060 (B2)	W130 (G2)	W211 (D1)	W318 (B4)	W415 (H5)	ZD805 (B5)	
C3A41 (G5)	C6P08 (B3)	JC801 (A6)	Q802 (C4)		SW720 (B0)	W061 (H0)	W131 (B1)	W212 (B3)	W319 (C4)	W416 (H5)	ZD806 (B4)	
C3D01 (E5)	C6P10 (B3)	JC802 (C6)	Q803 (C4)		TM401 (A6)	W062 (G0)	W132 (G2)	W213 (D0)	W320 (C4)	W419 (G5)	ZD807 (C4)	
C3D02 (E5)	C6P11 (A3)	L1SS02 (K5)	Q804 (C4)		TP301 (J5)	W063 (B2)	W133 (G2)	W214 (A6)	W321 (B5)	W420 (D5)		
C3D03 (E5)	C6P12 (A3)	L1SS31 (K1)	Q806 (B5)									
C3S02 (B1)	C701 (G0)		Q809 (F4)									
C3S04 (C1)	C801 (A5)		Q810 (A4)									
C3S05 (C1)												

MEMO

10. Schematic Diagrams

◆ Block Identification of Main PCB - - - - -	10-2
10-1 S.M.P.S. - - - - -	10-3
10-2 Power - - - - -	10-4
10-3 System Control/Servo/Display - - - - -	10-5
10-4 Audio/Video - - - - -	10-6
10-5 TM-Block - - - - -	10-7
10-6 SECAM - - - - -	10-8
10-7 OSD/VPS/PDC - - - - -	10-9
10-8 Input-Output - - - - -	10-10

Note

For schematic Diagram
 - Resistors are in ohms, 1/8W unless otherwise noted.

Special note :

Most semiconductor devices are electrostatically sensitive and therefore require the special handling techniques described under the "electrostatically sensitive (ES) devices" section of this service manual.

Note :

Do not use the part number shown on this drawing for ordering. The correct part number is shown in the parts list (may be slightly different or amended since this drawing was prepared).

Important safety notices :

Components identified with the mark  have the special characteristics for safety. When replacing any of these components. Use only the same type.

◆ **Block Identification of Main PCB**

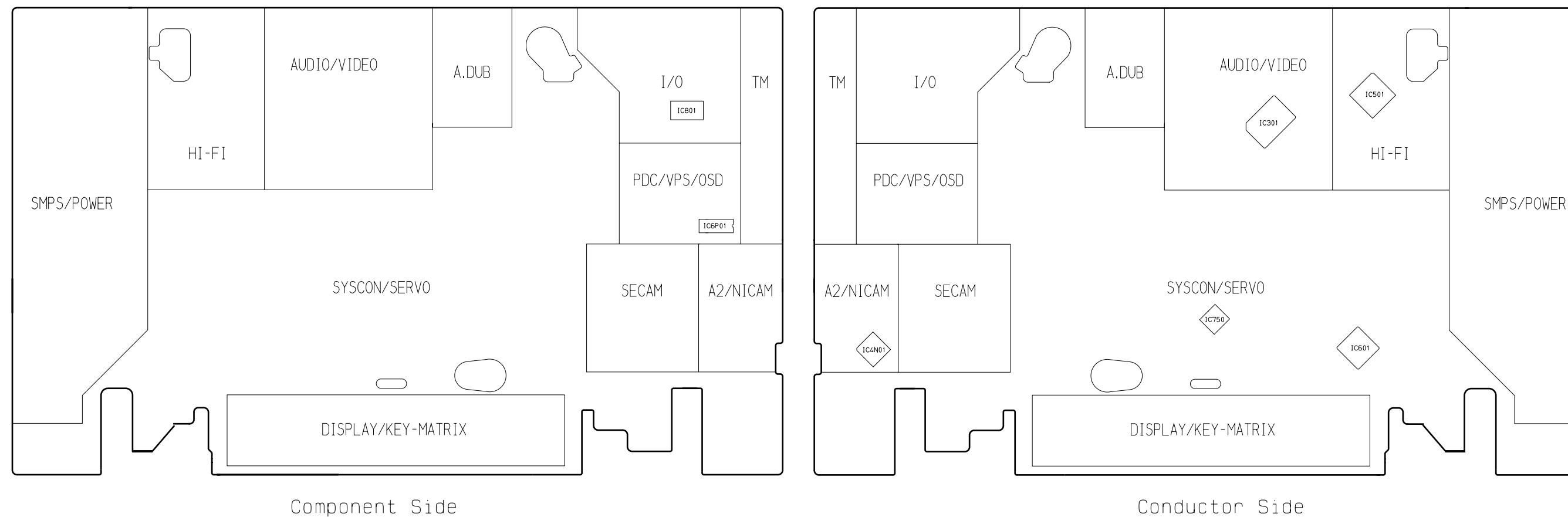

10-1 S.M.P.S.

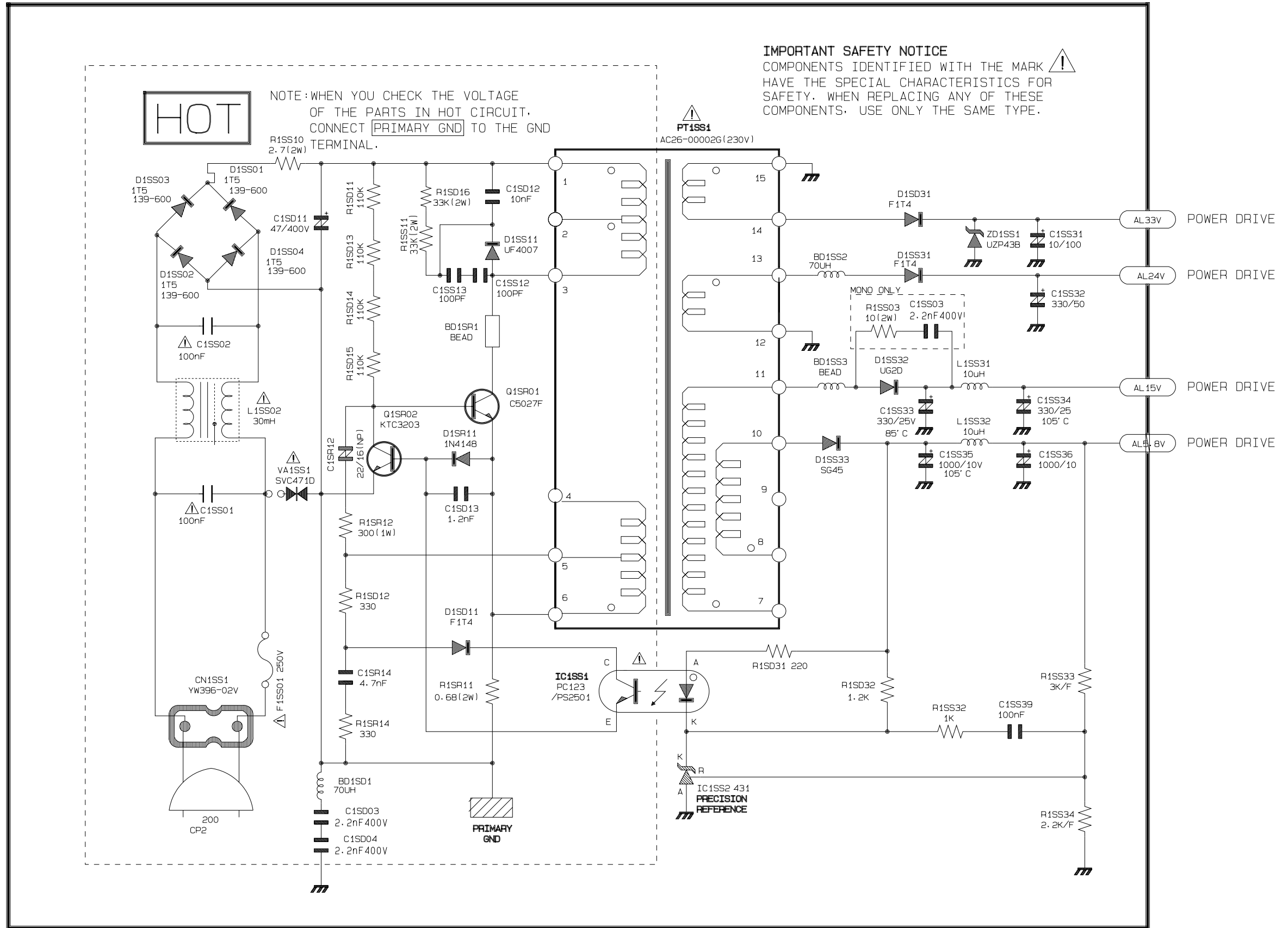

10-2 Power

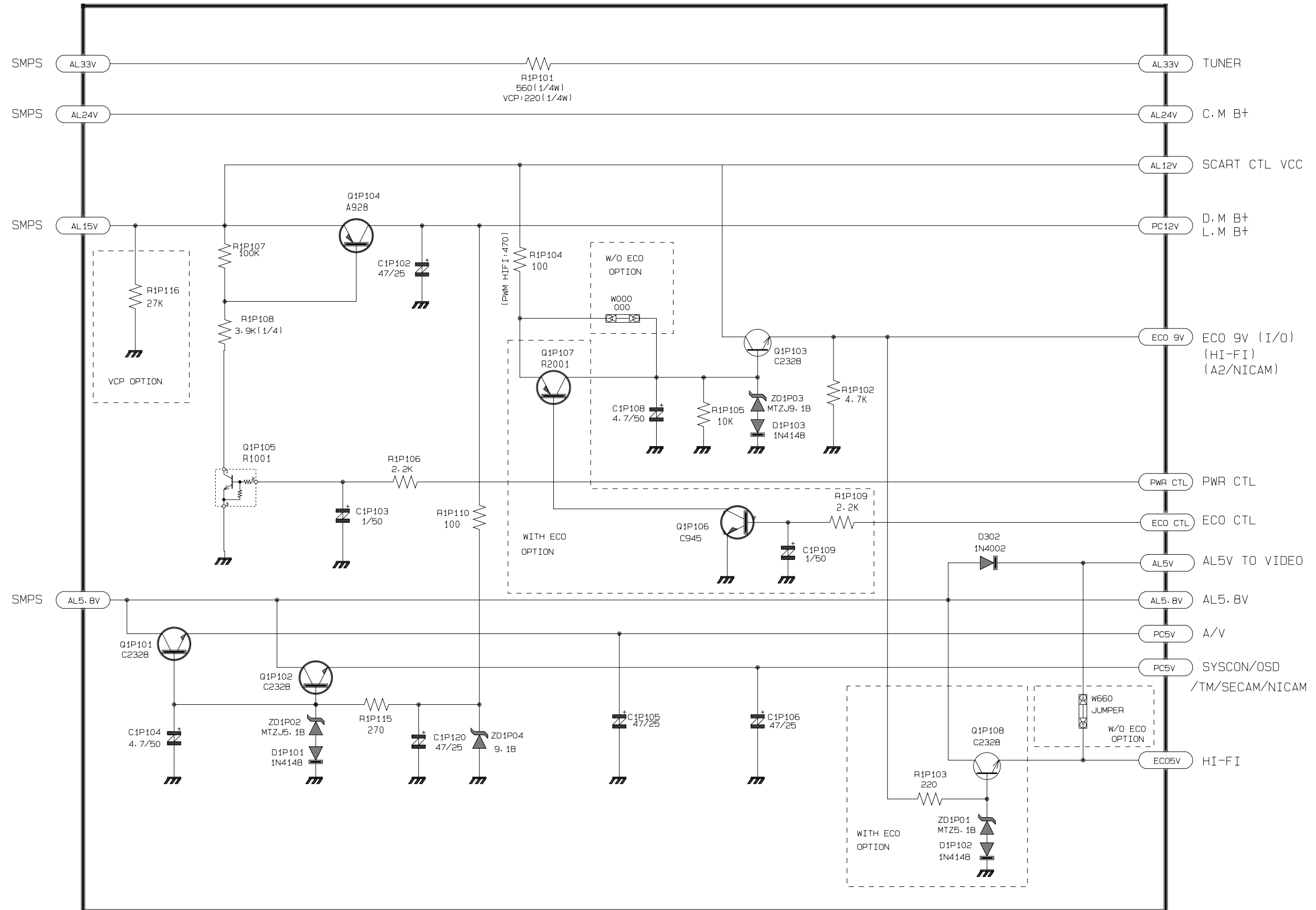

10-3 System Control/Servo/Display

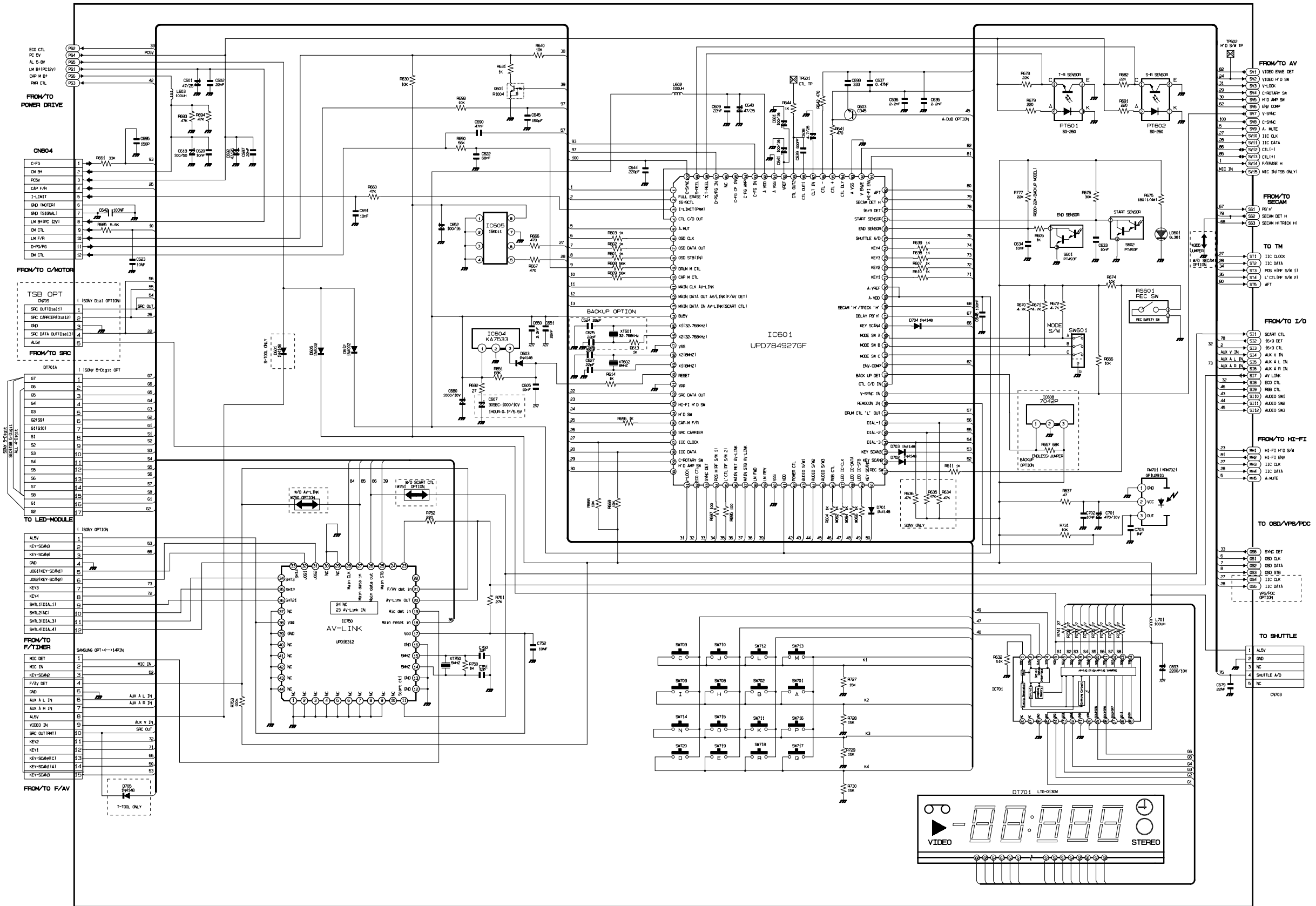

10-4 Audio/Video

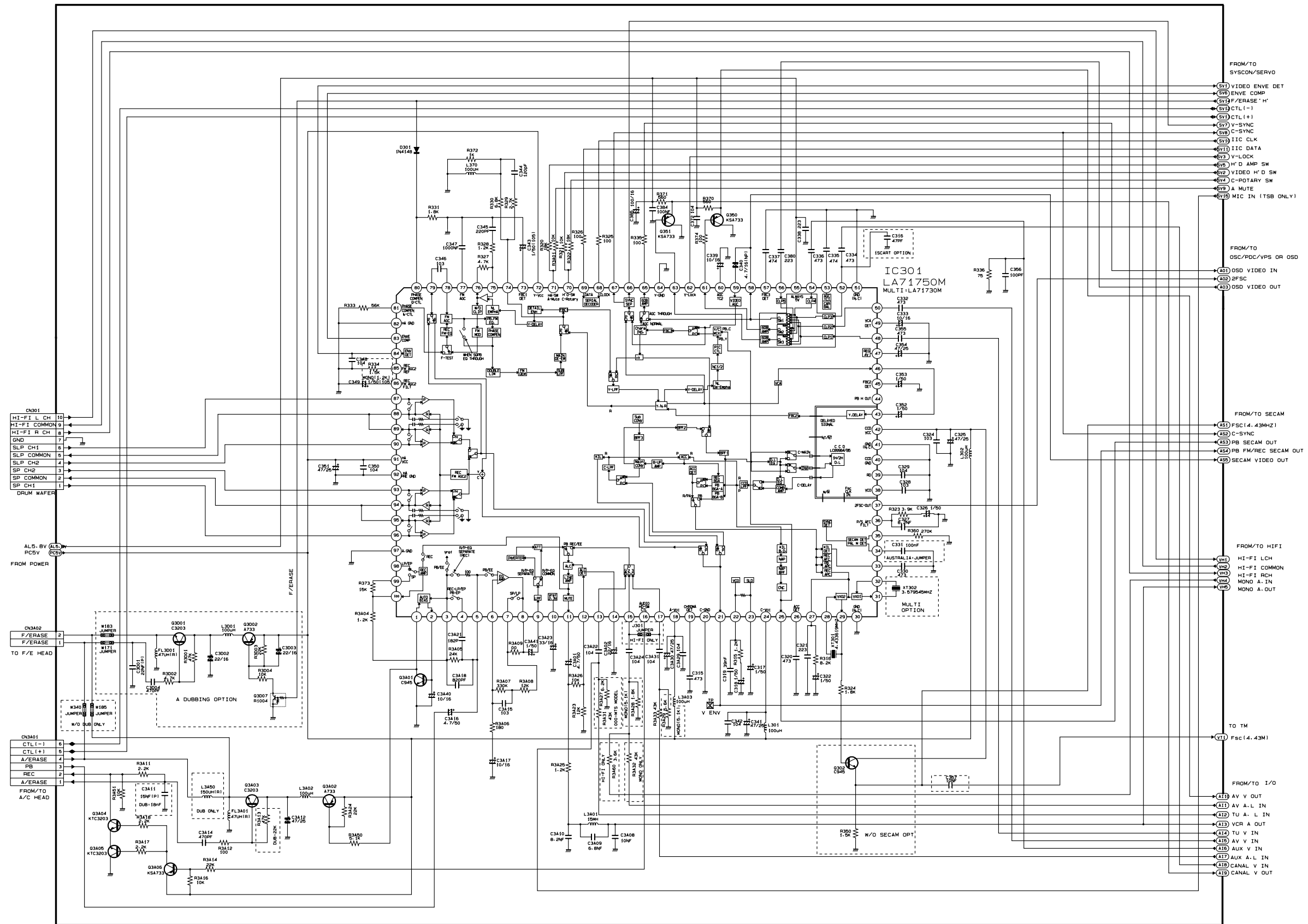

10-5 TM-Block

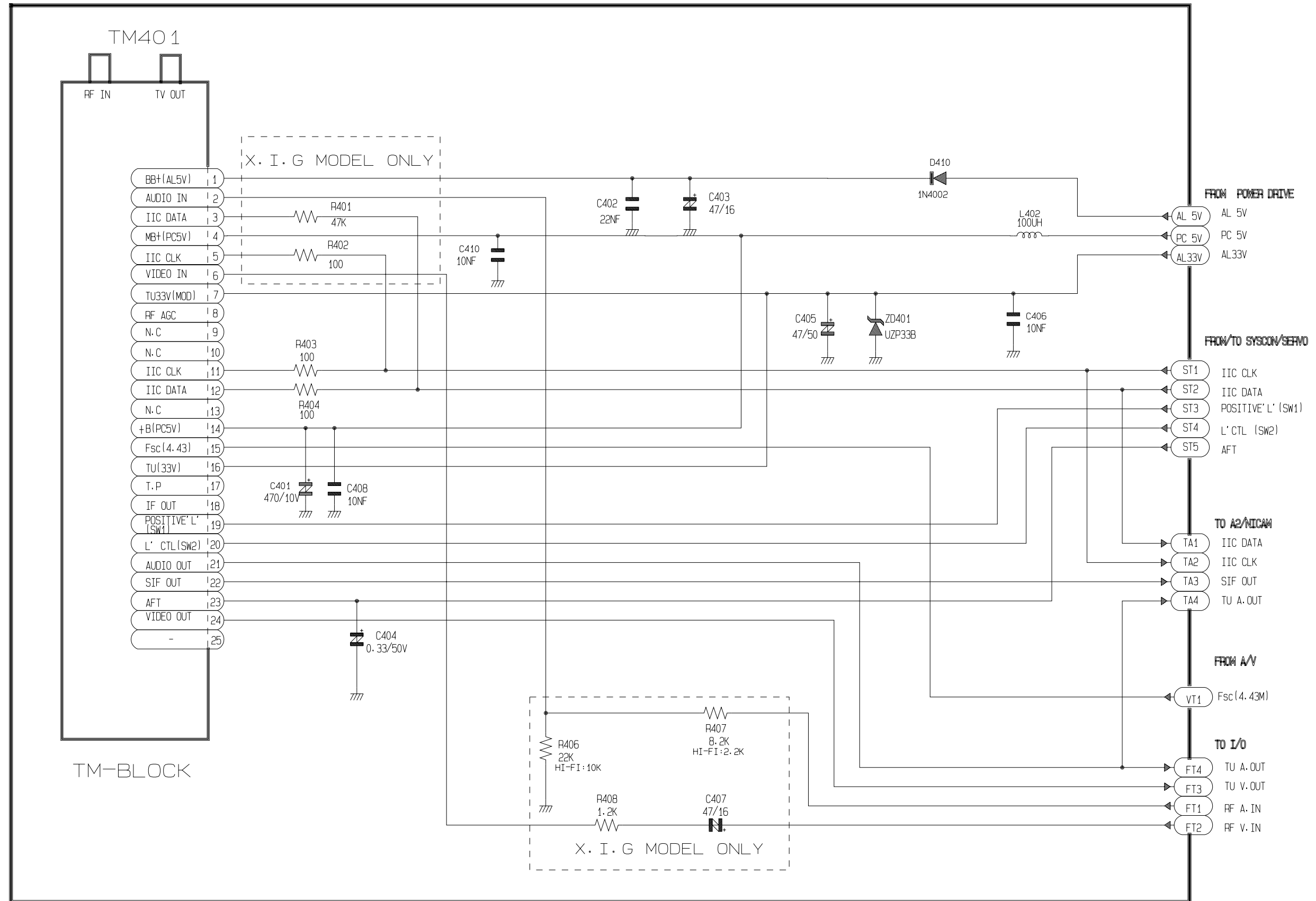

10-7 OSD/VPS/PDC

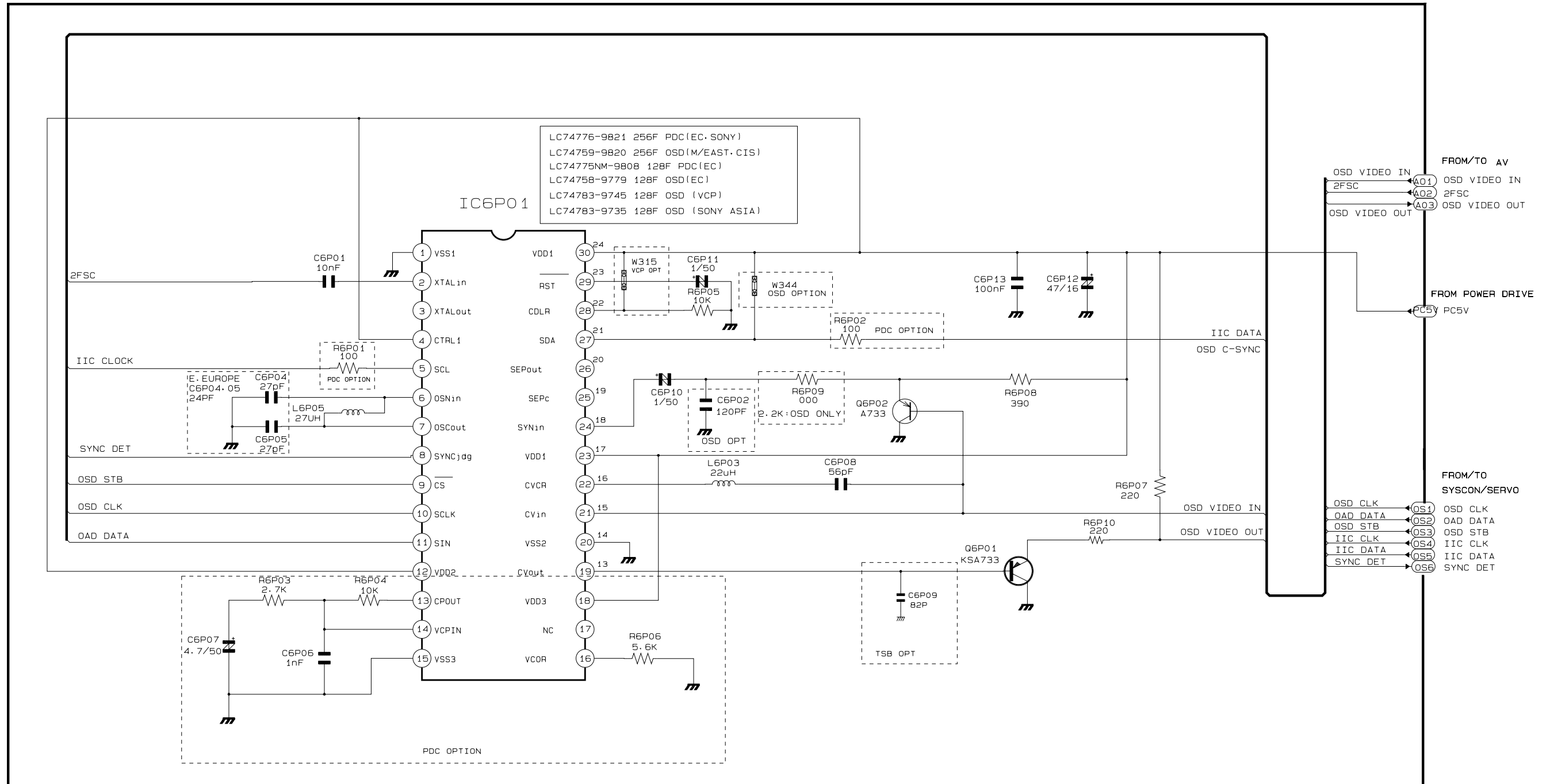

10-8 Input-Output

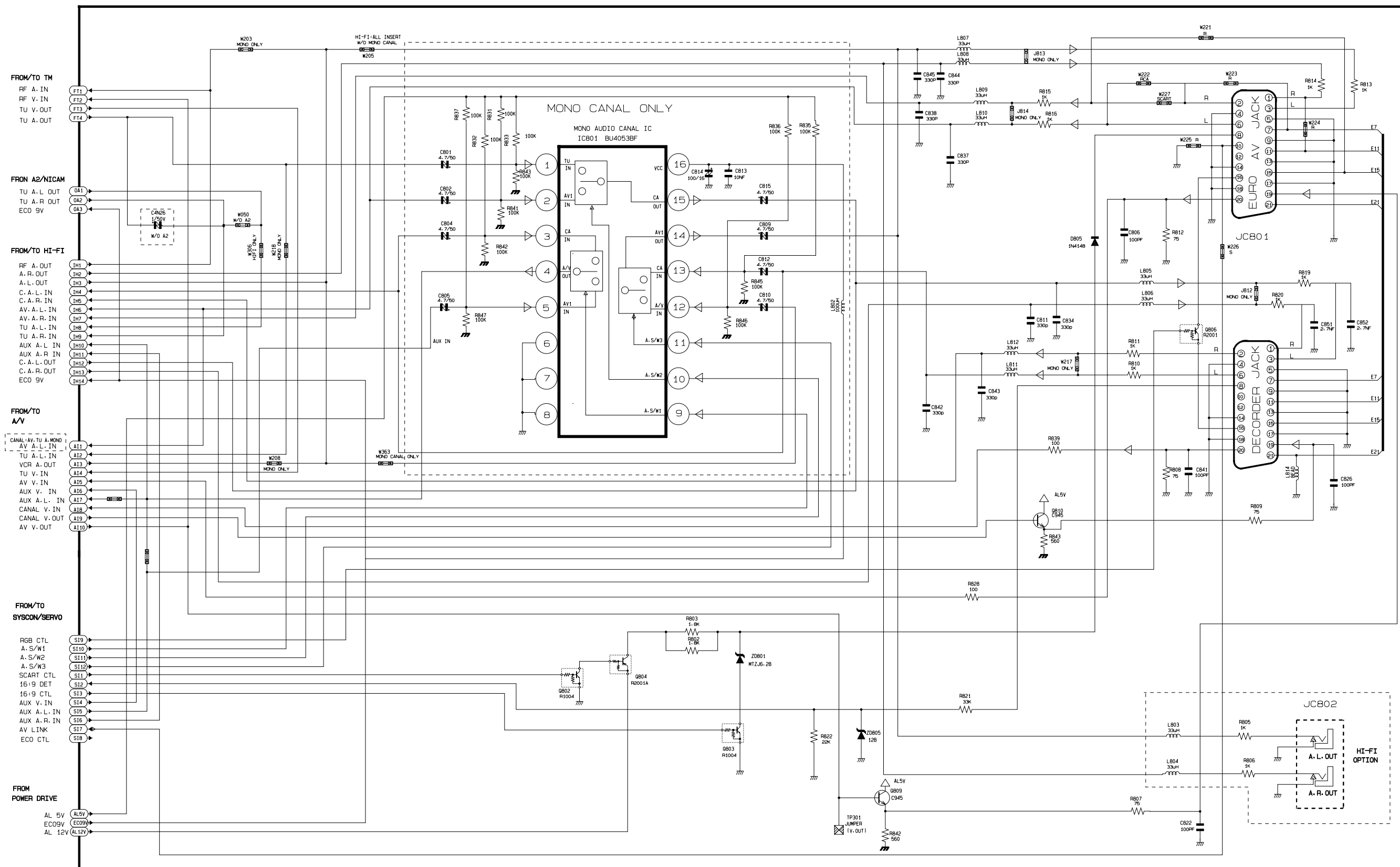

TOSHIBA VIDEO PRODUCTS PTE LTD

438B ALEXANDRA ROAD BLOCK B #06-01
ALEXANDRA TECHNOPARK
SINGAPORE 119968